

4K NDI POV Camera

Ultra compact, POE, multiple streaming and NDI@HX3

ZowieCAM 4K POV camera is a ultra compact , durable aluminum body, 4K Ultra HD video camera with streaming capability plus featuring NDI@|HX3, PoE and distinct tally light. It is rugged, small form-factor, light weight and professional for critical streaming applications. It is cost effective, easy to use, user friendly with multiple standard tripod mount. ZowieCAM supports popular USB Type-C charger, PoE 802.3at and a range of innovative modern features. It is a standalone steaming IP camera with HDMI and SDI output, no PC required.

Compact ZowieCAM has three standard 1/4" tripod mounts and gyroscope detection. The design makes it flexible to mount anywhere but always with correct video direction automatically. And portrait light can also be mounted on it. When mounting in 90 degree, it will output vertical video for portrait, this vertical video is best for mobile video eco-system.

It has three lens optional models: M12, VCM and CS. They are all interchangeable lens mount. Built-in swappable fixed lens of M12 and VCM make the camera plug and play. CS mount has a vast of CS/C lens options that make the camera so flexible to fit the target application for unlimited possibilities. For M12 AF camera by the way, it has auto focus feature that makes the focus accurate and video crisp sharp.

The Sony Ultra-HD 4K back-illuminated and stacked sensor offers crystal clear and rich color accurate video with improved low light sensitivity. It has 4K HDMI, 3G SDI and NDI output simultaneously with embedded audio.

Streaming on-the-go, turn compact ZowieCAM into NDI enabled real-time, low-latency high-quality video over IP workflow. NDI@|HX3 is even better than or equivalent to USB camera. It allows seamless integration of the camera to any NDI environments over a single network cable.

The camera can be powered by any handy USB type C power adapter, any DC power adapter via type C to DC adapter or PoE up to 100 meters. Single cable for Video, Audio, Power and Tally in addition to NDI. All above makes it can be easily installed anywhere.

Build-in rear button can help to setup the camera quickly and conveniently in the field. You can even watch the camera video and setup the camera by the phone besides HDMI or SDI monitor.

The camera has built-in Tally light for multi-camera live production. It supports VISCA over IP or NDI full control from a distance.

The state-of-art, all-in-one ZowieCAM POV cameras offer system integrators, streaming professionals, scientific researchers and OEM partners a flexible and affordable solution to stream high quality video over network and video source.



Highlights :

- ◇ Sony Ultra-HD 4K back illuminated and stacked 1/2.3" sensor
- ◇ Crispily-detail, low noise 4K video
- ◇ Interchangeable M12, M12 AF, CS lens
- ◇ Built-in tally light PVW/PGM in multi-camera productions
- ◇ Accurate auto exposure with zone option
- ◇ Auto, manual, color temp, one push white balance
- ◇ Image freeze support
- ◇ Simultaneous 4K HDMI and 3G SDI outputs with embedded audio
- ◇ Up to 4K30 hardware video encoder
- ◇ H.264 HP/MP/BP or H.265/HEVC MP codec
- ◇ NDI@ | HX3 support with better quality and very smallest delay
- ◇ Up to 50mbps bitrate, high bandwidth video stream for best quality
- ◇ NDI@ | HX, RTSP, SRT, RTMP(s) steaming up to 4K30
- ◇ Low latency SRT streaming
- ◇ Direct standalone streaming to CDN like YouTube, no PC required
- ◇ Video scale down, Vertical/Portrait crop and rotation streaming support
- ◇ Simultaneous live out in different RTMP SRT RTSP and multiple CDN
- ◇ Adaptive AAC audio for both embedded audio and analog
- ◇ Analog stereo line in audio input
- ◇ IP VISCA control, NDI@ and Web control
- ◇ Simple setup and configuration via login protected web interface
- ◇ Comprehensive control via by PC, smartphone, iPad, Controller and Panel
- ◇ Live video feed to PC, phone and iPad
- ◇ Flexible WYSIWYG OSD, text, logo and stamp image overlay, user-friendly
- ◇ Easy access and plug-and-play installation by mDNS
- ◇ Automatic rotation for vertical/portrait output and encoding
- ◇ Multiple standard tripod mounts also for vertical/portrait video
- ◇ Handy and convenient USB-C, DC, or single cable PoE power
- ◇ RESTFUL API supported for DIY automation and system integrator
- ◇ With 3 standard 1/4" camera tripod mount
- ◇ OEM/ODM support

4K NDI POV Camera

H.264/H.265 HEVC, Low latency, Multiple Streaming and Live Video Preview

Specification

Power:

Input : USB TYPE C, DC to USB C Adapter support
Up to 20V 0.5A, 12W and above
: PoE(802.3af), CAT5e above

Consumption : <12W Max

Camera:

Sensor size : Sony 1/2.3"
Back-illuminated and stacked Exmor R CMOS

Effective Pixels : 8Mega Pixels, 3840(H) x 2160(V)

Electronic Shutter : AUTO, 1/25, 1/30, 1/50, 1/60, 1/90, 1/100, 1/120, 1/125, 1/180, 1/250, 1/300, 1/350, 1/500, 1/600, 1/725, 1/1000, 1/1500, 1/2000, 1/3000, 1/4000, 1/6000, 1/10000

Aperture/IRIS : F2.2, Default factory installed lens

Gamma Control : 9 options

Noise Reduction : 2D/3D

White Balance : Auto, One Push, R/B Gain, Color Temp, Lock

Color Temp. : 3000-6500K

Focus : Manual for all, AF for VCM

Exposure : Auto, Shutter Priority, Manual

Gain : 0 ~ 16 steps

Focal Length : 7.2mm, Default factory install lens

Lens Mount : M12, CS Interchangeable

Lens Weight : <16g, for AF Camera, <10g recommended

Zoom Ratio : Depend on Lens. CS only

Mirror/Flip : Automatically

FOV(D/H/V) : 48.3°/42.6°/24.6°, Distortion < 1%

Lens : 4K 8M Pixel M12 Non-Distortion Lens
*M12 Lens shipping with camera, CS Lens not included

Video:

Video Encoder : H.264 HP/MP/BP, H.265 MP

Resolution : 4K2160p25/30, 1080p25/30/50/60
1080i50/60, 720p50/60

Frame Rate : 24/25/30fps, 50/60fps for 1080/720p

Codec : H.264/H.265

Rate Control : CBR/VBR

Live Preview : Web, HDMI output

OSD : English/Chinese, WYSIWYG editor

Network:

LAN : 100/1000Mbps Gigabit

Web : http, https

Streaming:

Streaming Out : RTMP(s)/SRT/RTSP

Bit Rate : Max. 50mbits/s, adjustable

NDI® : NDI® | HX3/HX2/HX (NDI v5.5, upgradeable)

Recorder : mp4, mov

Main Video Stream : Up to 4K

Secondary Stream : Up to 720p

Rotation : 0/90/180/270°, native vertical streaming

Video

HDMI Out : 1.4b, 4:2:2(YCbCr)

SDI Out : 3G SDI, 800mVpp, 75ohm, 4:2:2(YCbCr)

NDI : NDI | HX, HX2, HX3

Configuration :

Setting : Mobile Phone, Pad, PC, RESTFUL API

OSD : Text, Logo Caption

Camera Control:

Protocol : VISCA over IP, NDI®, Web, OnVIF

Local : Rear 5 button menu control

WEB : Browser GUI from desktop or mobile

Audio :

Sampling : 32, 44.1, 48KHz

Encoder : AAC, MP3, 16bit

Bitrate : 32-192kbps

Line Input : 0.7VRMS, 20K, 2CH, AGC

Source : Line In

Audio Embedding : HDMI, SDI and NDI

Tally:

Tally LED : Auto/Manual

Storage

Network : NAS

Recorder : mp4, mov, ts

Software

Firmware : Upgradeable, Linux OS

Interface:

Power : 1 x USB TYPE C, PoE

HDMI Input : 1 x TYPE A, Receptacle, 1.4b

Audio In : 1 x 3.5mm TRS Jack

Network : 1 x RJ45, Gigabit, PoE

USB : 1 x USB, Type A

Visible : 1 x LED, Rear

SDI : 1 x BNC Full size

Tally : 2 x LED, Front

Physical

Body size : 55.6L x 52D x 47.7H mm(2.18" x 2.05" x 1.87")

Weight : 166g (5.9oz), Black aluminum

Operating : 0°C to 45°C(32°F to 113°F), Indoor

Storage : -20°C to 60°C(-4°F to 140°F)

Mount : 1/4"- 20UNC x3 tripod

Certification

CE, FCC (In progress)

Ordering

30631-0YZ

Z=1, M12 Y=0, POV Camera

=2, AF M12 =1, NDI®|HX POV Camera

=3, CS

=4, C Silver, Black for all others

Accessories

USB TYPE C 25W PD Charger x 1

USB TYPE C Cable

4K M12 Lens x1

Quick Start Guide

CS/M12 Adapter (CS only)

C/CS Adapter (CS Only)

*Accessories is optional and sold separately

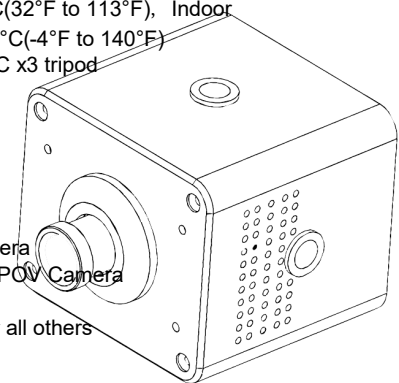

* All specifications are subject to change without notice.
* Accessories may be different for different product options.
* Actual object may differ from what shown in catalog.